



T260 and i200

- *Non-contact measurement of torque*
- *High stiffness and low inertia*
- *On-board shunt calibration circuit*
- *Internal zero velocity speed sensor (optional)*
- *i200 AC carrier electronics (optional)*
- *SAE 4340 alloy steel construction with satin nickel finish*

The T261 rotary transformer coupled torque sensor was designed for in-line testing of motors, engines, transmissions, propellers, pumps, drivelines, and similar rotating devices. The T261 has greater stiffness, less rotating inertia, and smaller size than comparable models available from other suppliers. The T261 requires the use of AC carrier strain gage signal conditioning electronics such as SensorData’s i200. The optional zero velocity speed sensor is installed inside the T261 housing. Interconnecting cable assemblies are available as an option. SensorData will provide in-house calibration of the T261 with customer-supplied electronics for a fee.

Specifications

(Subject to change without notice)

Rated Capacity	5K, 10K, 20K lb-in
Rated Speed	10,000 rpm
Nonlinearity	0.05% of rated output
Hysteresis	0.05% of rated output
Nonrepeatability	0.02% of rated output
Rated Output, bridge, typical	2 mV/V
Zero Balance	+/-0.5% of rated output
Temperature Range, operating	-20 to +200 F
Temperature Range, compensated	+68 to +170 F
Temperature Effect on Output	0.001% of load/F
Temperature Effect on Zero	0.001% of rated output/F
Bridge Resistance, typical	350 ohms
Excitation	2.8 to 5 VAC rms, 3 kHz to 5 kHz
Insulation Resistance, bridge to case	>5000 megohms at 50 VDC
Input voltage, speed sensor, V _{cc} (optional) ⁽¹⁾	4.5 to 24 VDC
Maximum Load, safe ⁽²⁾	200% of rated capacity
Maximum Load, ultimate ⁽³⁾	400% of rated capacity
Number of Bridges	1
Weight	11.5 lb without i200, 12.5 lb with i200
Construction	SAE 4340 alloy steel with satin nickel finish

⁽¹⁾ Output is an open collector NPN with internal 4.7K ohm pull up resistor

⁽²⁾ With load centered, maximum torque that can be applied without producing a permanent shift in performance characteristics.

⁽³⁾ With load centered, maximum torque that can be applied without physical damage.

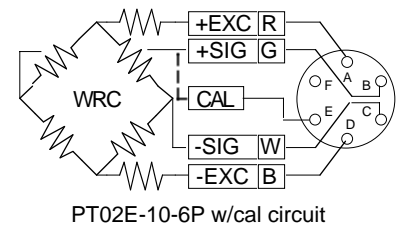
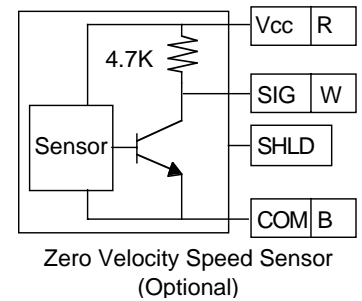
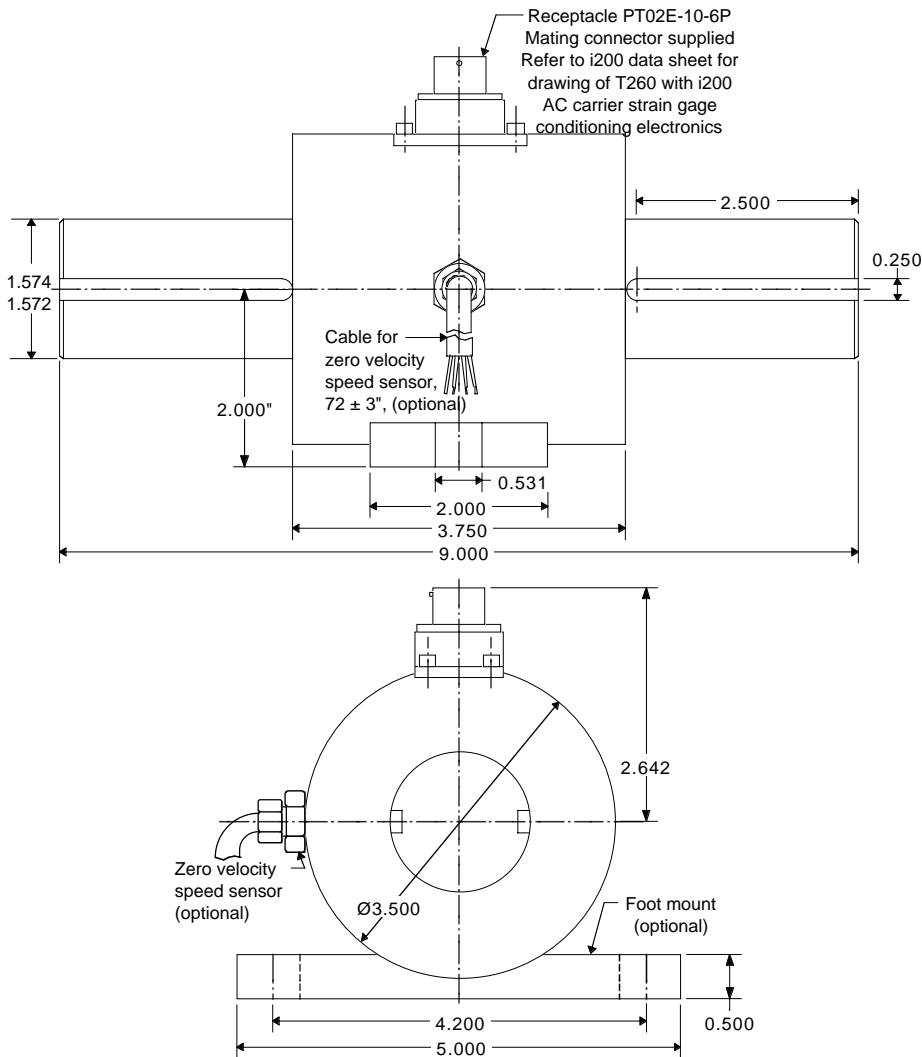

Capacity lb-in	Torsional Stiffness lb-in/rad	Rotating Inertia lb-in-sec ²
5K	1.18 x 10 ⁶	5.8 x 10 ⁻³
10K	1.28 x 10 ⁶	5.8 x 10 ⁻³
20K	5.56 x 10 ⁶	5.8 x 10 ⁻³

If the T261 is supplied with the optional SensorData i200 AC carrier strain gage conditioning electronics, the i200 instruction manual or data sheet should be referred to for wiring information and specifications.

ORDERING INFORMATION

T261-STD-Capacity	Standard with receptacle and mating connector.
T261-STD-Capacity-A	Same as T261-STD-Capacity except supplied with SensorData i200 strain gage conditioning electronics.
T261-STD-Capacity-S	Same as T261-STD-Capacity except supplied with zero velocity speed sensor.
T261-STD-Capacity-S-A	Same as T261-STD-Capacity except with zero velocity speed sensor & i200 strain gage conditioning electronics.
Foot Mount Option	Replace STD with 105 in above model designations; e.g., T261-105-Capacity-S-A
Cable Assembly	Optional; 10 ft., color coded, shielded, mating connector sensor end, customer specified connector instrument end.
Cable Assembly	Optional; 10 ft., color coded, shielded, mating connector sensor end, leads stripped and tinned instrument end.
Note	Mounting hardware is optional and not included unless specified at time of order

IMPORTANT NOTICE

Dimensions above are in inches unless otherwise noted. Manufacturer not responsible for any modification to product, fixtures, or accessories made by user or third party. User should request certified drawings before designing mountings or fixtures. Manufacturer reserves right to modify or change design, dimensions, specifications, and features of this product without prior written notice. Changes to NOTICE must be in writing and accepted by manufacturer.

SensorData Technologies, Inc., 43626 Utica Road, Sterling Heights, MI 48314

Ph: (586) 739-4254 - Fax: (586) 739-5689 - E-mail: sensdata@aol.com - Web: www.sensordata.com