



- Capacities from 5K to 20K lb-in
- High stiffness and low inertia
- On-board shunt calibration circuit
- i200 AC carrier electronics (optional)
- Internal zero velocity speed sensor (optional)
- SAE 4340 alloy steel construction with satin nickel finish

The T251 rotary transformer coupled torque sensor was designed for in-line testing of propellers, pumps, drivelines, and other devices where there is minimal axial space available for the torque sensor. The T251 requires the use of AC carrier strain gage signal conditioning electronics such as SensorData's i200. The optional zero velocity speed sensor is installed inside the T251 housing. Interconnecting cable assemblies are available as an option. SensorData will provide in-house calibration of the T251 with customer-supplied electronics for a fee.

Specifications

(Subject to change without notice)

Rated Capacity	5K, 10K, 20K, lb-in
Rated Speed	10,000 rpm
Nonlinearity	0.05% of rated output
Hysteresis	0.05% of rated output
Nonrepeatability	0.02% of rated output
Rated Output, typical	2 mV/V
Zero Balance	+/-0.5% of rated output
Temperature Range, operating	-20 to +200 F
Temperature Range, compensated	+68 to +170 F
Temperature Effect on Output	0.001% of load/F
Temperature Effect on Zero	0.001% of rated output/F
Bridge Resistance, typical	350 ohms
Excitation	2.8 to 5 VAC rms, 3 kHz to 5 kHz
Insulation Resistance, bridge to case	>5000 megohms at 50 VDC
Input voltage, speed sensor, V _{cc} (optional) ⁽¹⁾	4.5 to 24 VDC
Maximum Load, safe ⁽²⁾	200% of rated capacity
Maximum Load, ultimate ⁽³⁾	400% of rated capacity
Number of Bridges	1
Weight	12 lb without i200, 13 lb with i200
Construction	SAE 4340 alloy steel with satin nickel finish

⁽¹⁾ Output is an open collector NPN with internal 4.7K ohm pull up resistor

⁽²⁾ With load centered, maximum torque that can be applied without producing a permanent shift in performance characteristics.

⁽³⁾ With load centered, maximum torque that can be applied without physical damage.

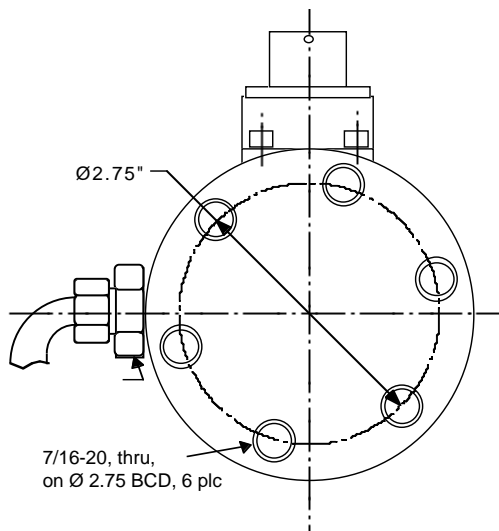
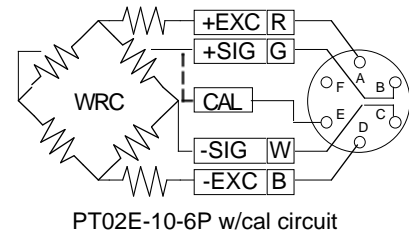
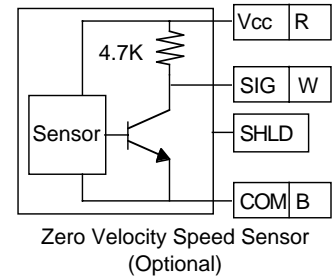
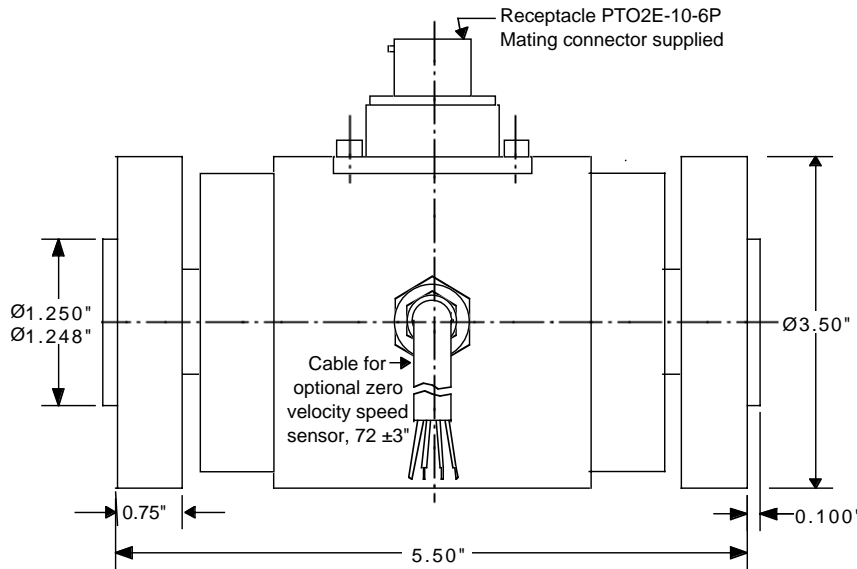

Capacity lb-in	Torsional Stiffness lb-in/rad	Rotating Inertia lb-in-sec ²
5K	1.95 x 10 ⁶	1.16 x 10 ⁻²
10K	2.64 x 10 ⁶	1.16 x 10 ⁻²
20K.	5.96 x 10 ⁶	1.16 x 10 ⁻²

If the T251 is supplied with the optional SensorData i200 AC carrier strain gage conditioning electronics, the i200 instruction manual or data sheet should be referred to for wiring information and specifications.

ORDERING INFORMATION

- T251-STD-Capacity Standard with receptacle and mating connector.
- T251-STD-Capacity-A Same as T251-STD-Capacity except supplied with SensorData i200 strain gage conditioning electronics.
- T251-STD-Capacity-S Same as T251-STD-Capacity except supplied with zero velocity speed sensor.
- T251-STD-Capacity-S-A Same as T251-STD-Capacity except with zero velocity speed sensor & i200 strain gage conditioning electronics.
- Cable Assembly Optional; 10 ft., color coded, shielded, mating connector sensor end, customer specified connector instrument end.
- Cable Assembly Optional; 10 ft., color coded, shielded, mating connector sensor end, leads stripped and tinned instrument end.
- Note Mounting hardware is optional and not included unless specified at time of order

IMPORTANT NOTICE

Dimensions above are in inches unless otherwise noted. Manufacturer not responsible for any modification to product, fixtures, or accessories made by user or third party. User should request certified drawings before designing mountings or fixtures. Manufacturer reserves right to modify or change design, dimensions, specifications, and features of this product without prior written notice. Changes to NOTICE must be in writing and accepted by manufacturer.