



- *High torsional stiffness*
- *Fatigue rated*
- *0.1% accuracy*
- *Capacities 1K to 1000K lb-in*
- *SAE 4340 Alloy Steel*
- *Supplied with mating connector*

SensorData's T150 Series of fatigue rated flange coupled torque sensors is designed for use during life testing and "test-to-failure" of drive-line components and where there is a small degree of angular rotation or reciprocating motion involved. The T150 Series with inherent low-end measurement capability can be installed at the driver or absorber end of the measurement chain. Each flange face is provided with a pilot diameter to assist installation. AC carrier or DC strain gage signal conditioning electronics can be used with the T150 Series. Interconnecting cable assemblies are available as an option. In-house calibration of the T150 Series with SensorData's electronics will be provided free of charge or with customer-supplied electronics for a fee.

## Specifications

(Subject to change without notice)

Rated Capacity	1K, 2K, 5K, 10K, 20K, 50K, 100K, 200K, 500K, 1000K lb-in
Nonlinearity	0.10% of rated output
Hysteresis	0.10% of rated output
Nonrepeatability	0.05% of rated output
Rated Output, typical	2.00 mV/V
Zero Balance	+/-1% of rated output
Temperature Range, operating	-65 to +200 F
Temperature Range, compensated	+70 to +170 F
Temperature Effect on Output	0.002% of load/F
Temperature Effect on Zero	0.002% of rated output/F
Bridge Resistance, typical	350 ohms
Excitation Voltage, bridge, typical	10 VDC or VAC rms
Excitation Voltage, bridge, maximum <sup>(1)</sup>	20 VDC or VAC rms
Insulation Resistance, bridge to case	>5000 megohms at 50 VDC
Maximum Load, safe <sup>(2)</sup>	150%
Maximum Load, ultimate <sup>(3)</sup>	300%
Torsional Stiffness, typical	See table next page
Extraneous Loads, maximum	See table next page
Number of Bridges	1
Weight	Consult factory
Construction	SAE 4340 Alloy Steel

<sup>(1)</sup> Temperature gradients caused by higher excitation voltages may effect performance.

<sup>(2)</sup> With load centered maximum torque that can be applied without producing a permanent shift in performance characteristics.

<sup>(3)</sup> With load centered maximum torque that can be applied without physical damage.

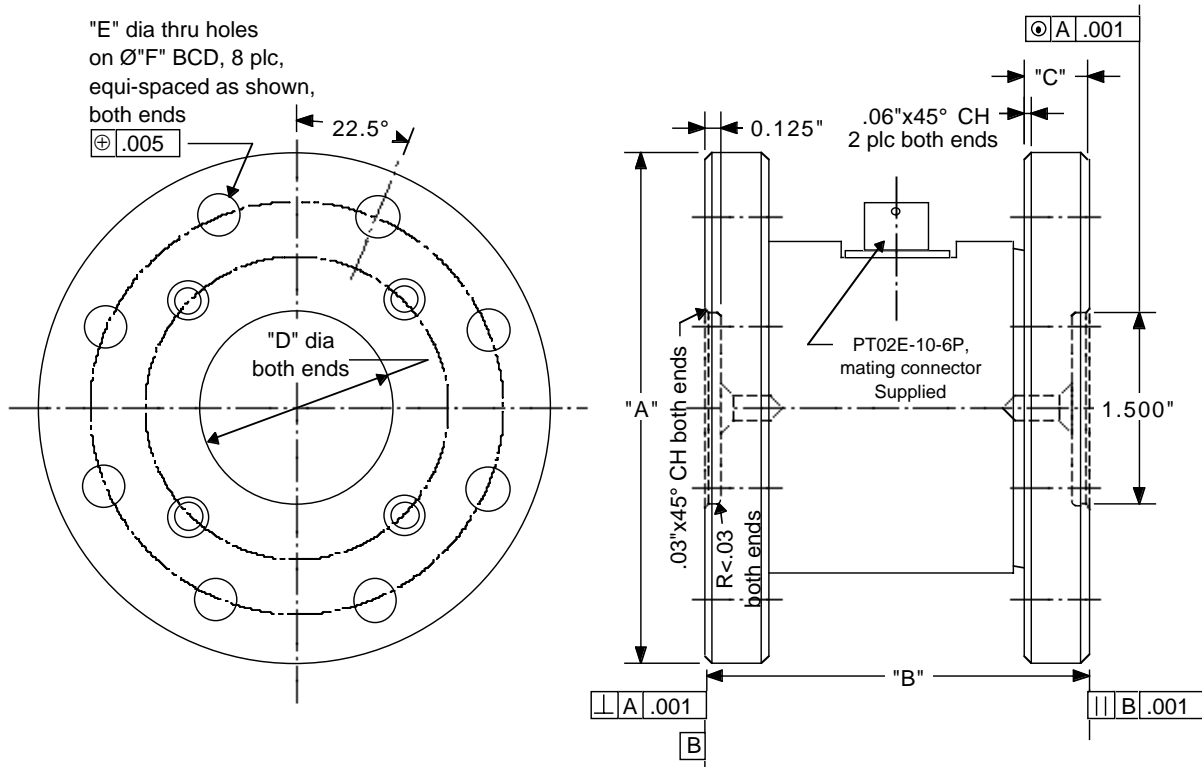

Model	Cap (lb-in)	A	B	C	D	E	BCD $\oplus .005$ F	Torsional Stiffness $\times 10^6$ lb-in/rad	Maximum		
									OH Moment W x L lb-in	Shear W lb	Thrust T lb
T150	1K, 2K, 5K	4.000	3.000	0.500	1.500	0.328	3.250	0.95	2,000	2,000	3,000
T153	10K, 20K	5.000	3.500	0.750	2.000	0.391	4.250	2.8	5,000	9,000	6,000
T155	50K, 100K	8.000	7.375	1.500	3.500	0.641	6.500	8.4	26,000	15,000	20,000
T156	100K, 200K	9.750	8.500	1.500	4.000	0.766	8.000	35	100,000	36,000	42,000
T157	500K, 1000K	14.000	10.500	2.000	6.000	1.102	11.000	200	400,000	160,000	150,000

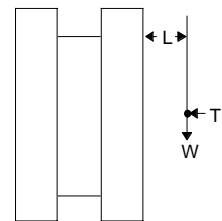

Do not exceed the maximum overhung moment or shear, whichever occurs

### ORDERING INFORMATION

T150-Capacity	Standard; supplied with receptacle and mating connector.
T153-Capacity	Standard; supplied with receptacle and mating connector.
T155-Capacity	Standard; supplied with receptacle and mating connector.
T156-Capacity	Standard; supplied with receptacle and mating connector.
T157-Capacity	Standard; supplied with receptacle and mating connector.
Cable Assembly	Optional; 10 ft., color coded, shielded, mating connector sensor end, customer specified connector instrument end.
Cable Assembly	Optional; 10 ft., color coded, shielded, mating connector sensor end, leads stripped and tinned instrument end.

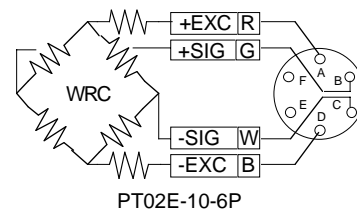

### IMPORTANT NOTICE

Dimensions above are in inches unless otherwise noted. Manufacturer not responsible for any modification to product, fixtures, or accessories made by user or third party. User should request certified drawings before designing mountings or fixtures. Manufacturer reserves right to modify or change design, dimensions, specifications, and features of this product without prior written notice. Changes to NOTICE must be in writing and accepted by manufacturer.

**SensorData Technologies, Inc.**, 43626 Utica Road, Sterling Heights, MI 48314

Ph: (586) 739-4254 - Fax: (586) 739-5689 - E-mail: sensdata@aol.com - Web: www.sensordata.com