

Fatigue Rated Low Profile Universal Shear Web Load Cell F341, F342, F344, F346, F347



F342

- Fully fatigue rated shear web design
- Low profile
- Deflection less than 0.002 inch
- Tension plate & load button (optional)
- SAE 4340 alloy steel construction with satin nickel finish
- Supplied with mating connector

The F341 thru F347 are suitable for use in material testing machines, airframe test fixtures, and any application requiring a load cell that has a low profile, a high degree of stiffness, fatigue rating, and resistance to the negative effects of extraneous forces. For universal or tension only applications, the F341 thru F347 are usually bolted to a surface or plate that is flat and parallel within ± 0.0002 inch. For compression only applications, a load button with a spherical loading surface and with threads that will engage the threads found in the center-loading hole of the F341 thru F347 should be used. The F341 thru F347 can be used with AC carrier and DC strain gage signal conditioning electronics. Tension plates, spherical load buttons, and interconnecting cable assemblies are available as options. SensorData will provide in-house calibration of the F341 thru F347 with customer-supplied electronics for a fee.

Specifications

(Subject to change without notice)

Rated Fatigue Capacity	5K, 10K, 20K (F341), 50K (F342), 100K (F344), 250K (F346), 500K (F347) lbs
Nonlinearity	0.05% of rated output
Hysteresis	0.05% of rated output
Nonrepeatability	0.02% of rated output
Rated Output, typical	2 mV/V
Zero Balance	+/- 1% of rated output
Temperature Range, operating	-65 to +200 F
Temperature Range, compensated	+70 to +170 F
Temperature Effect on Output	0.002% of load/F
Temperature Effect on Zero	0.002% of rated output/F
Input Impedance, minimum	750 ohms
Output Impedance	700 +/- 5 ohms
Excitation Voltage, typical	10 VDC or VAC rms
Excitation Voltage, maximum ⁽¹⁾	20 VDC or VAC rms
Insulation Resistance	>5000 megohms at 50 VDC
Maximum Load, safe ⁽²⁾	150% of rated capacity
Maximum Load, ultimate ⁽³⁾	300% of rated capacity
Deflection at Rated Capacity, typical	0.002 in
Fatigue Rating, full fatigue capacity tension to full fatigue capacity compression load	10 ⁸ cycles
Number of Bridges	1, 2 nd bridge optional
Weight	Refer to table next page
Construction	SAE 4340 alloy steel with satin nickel finish

⁽¹⁾ Temperature gradients caused by higher excitation voltages may effect performance.

⁽²⁾ With load centered, maximum load that can be applied without producing a permanent shift in performance characteristics.

⁽³⁾ With load centered, maximum load that can be applied without physical damage.

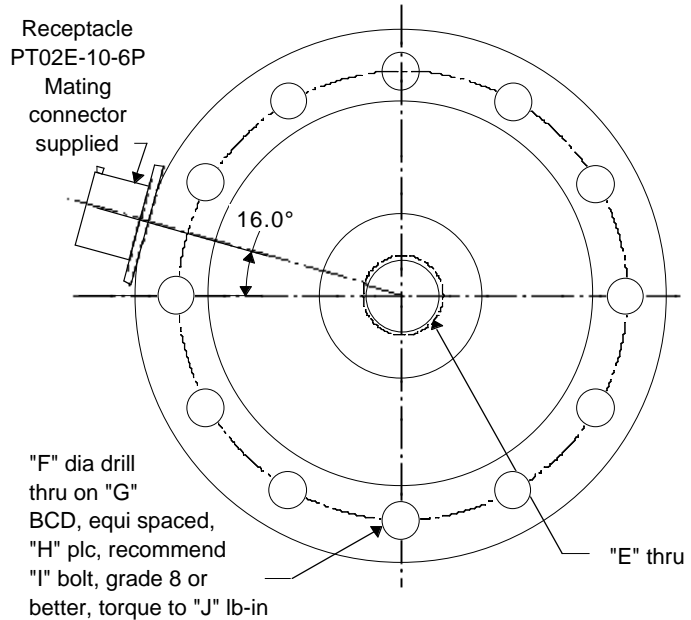
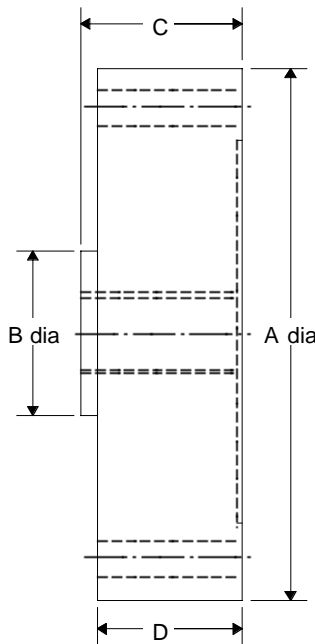

Model	A	B	C	D	E	F	G	H	I	J	Wgt
F341-110	6.060	2.420	1.625	1.500	1 1/4-12 UNF	0.406	5.125	12	3/8-24	600 lb-in	9 lb
F342-110	8.000	3.140	1.875	1.750	1 3/4-12 UNF	0.530	6.500	16	1/2-20	1,560 lb-in	15 lb
F344-110	11.000	4.920	3.500	3.375	2 3/4-8 UNF	0.656	9.000	16	5/8-18	3,000 lb-in	53 lb
F346-STD	12.000	5.340	4.000	3.940	3-12 UNF	0.656	10.000	16	5/8-18	3,000 lb-in	72 lb
F347-STD	14.000	6.340	4.000	3.940	3 1/2-12 UNF	0.781	12.000	16	3/4-16	4,980 lb-in	98 lb

It is recommended that the F341 thru F347 be mounted on the optional tension plate available from SensorData. If this is not practical, the F341 thru F347 should be mounted on a surface flat to 0.0002 inch and rigid enough not to deform under a load equal to 100% of load cell's rated capacity. Mounting bolts should be grade 8 or better. Request FAQ 9907/Q053 for a copy of Installation Information that applies to SensorData Shear Web Load Cells.

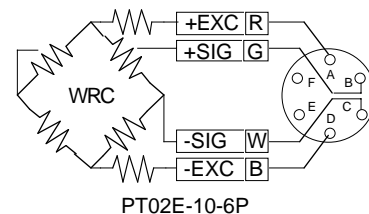

ORDERING INFORMATION

- F341-110-Capacity Standard, capacity 5K, 10K, 20K lb, and supplied with PT02E-10-6P receptacle and mating connector.
- F342-110-Capacity Standard, capacity 50K lb, and supplied with PT02E-10-6P receptacle and mating connector.
- F344-110-Capacity Standard, capacity 100K lb, and supplied with PT02E-10-6P receptacle and mating connector.
- F346-STD-Capacity Standard, capacity 250K lb, and supplied with PT02E-10-6P receptacle and mating connector.
- F347-STD-Capacity Standard, capacity 500K lb, and supplied with PT02E-10-6P receptacle and mating connector.
- Tension Plate Options Add T to Standard; e.g., F341-110-Capacity-T.
- Load Button Options Add L to Standard; e.g., F341-110-Capacity-L.
- Tension Plate and Load Button Options Add T and L to Standard; e.g., F341-111-Capacity-T-L.
- Cable Assembly Optional; 10 ft, color coded, shielded, mating connector sensor end, customer supplied connector instrument end.
- Cable Assembly Optional; 10 ft, color coded, shielded, mating connector sensor end, leads stripped and tinned instrument end.

IMPORTANT NOTICE

Dimensions above are in inches unless otherwise noted. Manufacturer not responsible for any modification to product, fixtures, or accessories made by user or third party. User should request certified drawings before designing mountings or fixtures. Manufacturer reserves right to modify or change design, dimensions, specifications, and features of this product without prior written notice. Changes to NOTICE must be in writing and accepted by manufacturer.